

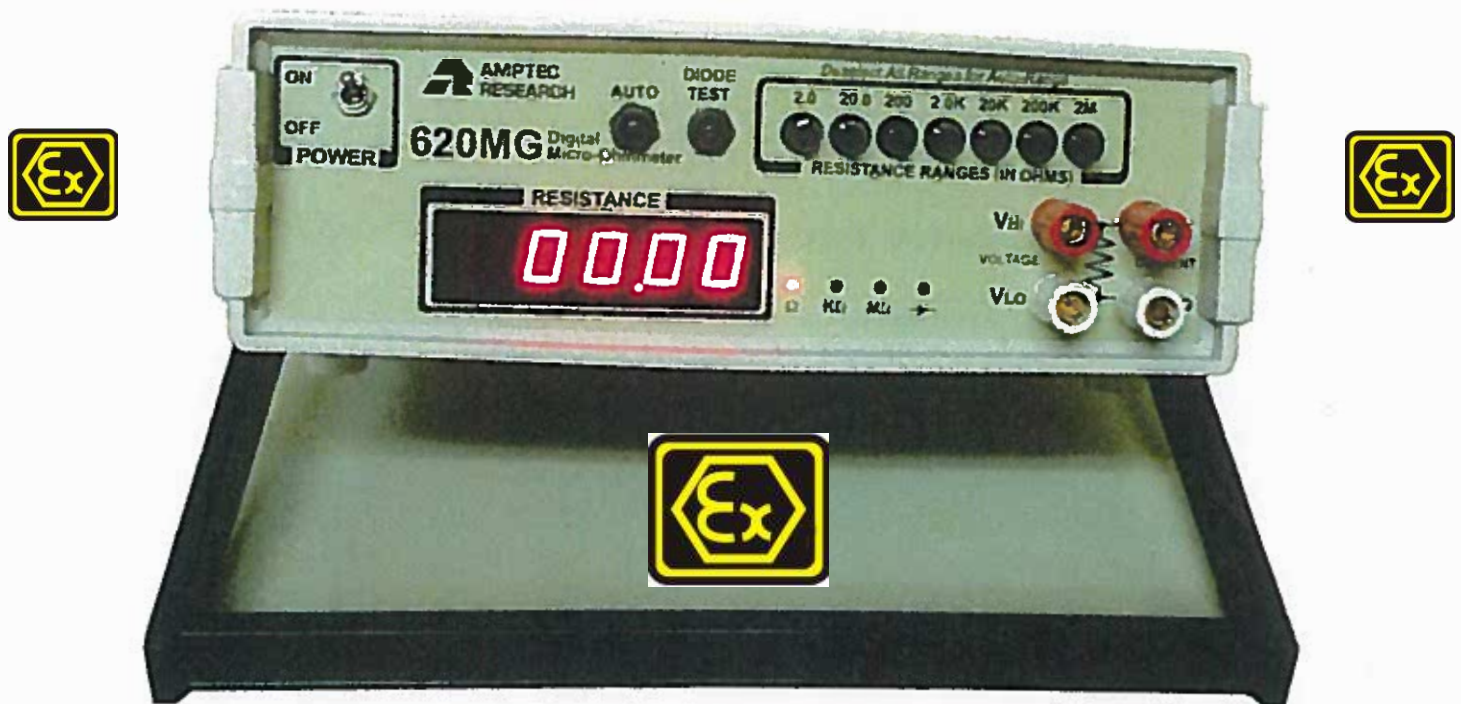

AMPTEC RESEARCH is an ISO 9001:2015 Certified Accredited Quality Management System Company



AMPTEC 620MG Igniter Tester OPERATION/MAINTENANCE MANUAL



Buy Test Equipment at Discount Prices
www.ATEquip.com
sales@ATEquip.com 858-756-8742

see website for latest address, contact information and updates <http://www.amptec.com>

AUSTIN, TEXAS USA - US DEFENSE LOGISTICS CAGE CODE 1CRL2
PHONE +001 (512) 858-4045 or 1-800-350-5105 (from the USA)
FAX +001 (512) 3858-4340 or 1-800-430-5440 (from the USA)

24FEB2015 REV. A
website <http://www.amptec.com>

A MESSAGE FROM THE PRESIDENT



We at AMPTEC RESEARCH would like to thank you, our customer, for selecting our Failsafe Igniter Tester/ Digital Ohmmeter. Over the past 36 years our experienced engineering staff have designed, manufactured and supplied earlier versions similar to the Model 620 and 620 Series Igniter Testers to the U.S. NAVY for the "TOMAHAWK CRUISE MISSILE", the U.S. ARMY for the "STANDARD MISSILE", the U.S.A.F. for the AIM-9 "SIDEWINDER", AIM-7 "SPARROW" and AIM-120 "AMRAAM" just to name just a few. We value the trust our customers have placed with us, and are looking forward to supporting any new requirement you may have

Kerry W Clark - President AMPTEC RESEARCH

U.S. N.I.S.T. CALIBRATION CERTIFICATE



AMPTEC RESEARCH, Inc. certifies that this instrument has been completely tested and inspected and found to meet published specifications as found in this manual on the date stated on the attached N.I.S.T. Certificate. AMPTEC RESEARCH, Corporation further certifies that its calibration measurements are traceable to the U.S. National Institute of Standards and Technology.

620 SERIES IGNITER TESTER WARRANTY



Permission and a return authorization (RMA) number must be obtained directly from AMPTEC's customer service department (via phone, FAX, or email) for repairs (warranty or otherwise). We need to issue you an RMA number so we can keep track of the instrument and it's owner (i.e. who to contact). The warranty period for this instrument is 1 year from when it was first shipped. AMPTEC RESEARCH will repair or replace the instrument during the warranty period provided it is returned to AMPTEC RESEARCH, freight prepaid. No other warranty is expressed or implied. We are not liable for consequential damages. No liability will be accepted if returned without such permission.

Some AMPTEC products may have their design frozen, and no changes will be made without prior notice to the proper approving authority. Through out this manual, there is reference made using to the generic model 620 series Igniter Testers. There are any versions of the 620 Igniter Tester specifically developed to meet our customers requirements. The specification, operation, drawing and schematic sections of this manual contain the unique detail that define the 620MG. Due to continuing product refinement, due to possible parts going obsolete and other component manufacturer changes, AMPTEC RESEARCH reserves the right on rare occasions to change any of its products specifications.

TABLE OF CONTENTS

CHAPTER A: RECEIVING AND INITIAL INSPECTION

- A-1 Introduction to the AMPTEC 620MG Igniter Tester
- A-2 Unpacking and Inspection
- A-3 Isolated Continuous Operating Power -
- A-4 Setup and Use



CHAPTER B: 620LM FAILSAFE OHMMETER SPECIFICATIONS

- Table B-2. Specifications



CHAPTER C: REPLACEMENT, OPTIONAL AND ACCESSORY ITEMS

- C-1 Available Accessories and Options
- C-2 Test Lead Sets

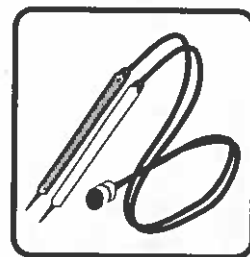

CHAPTER D: OPERATION, FUNCTION AND USE

- D-1 General
- D-2 Front Panel
- D-3 4-Wire Resistance Measurement
- D-4 Connections
- D-5 Failsafe Operation

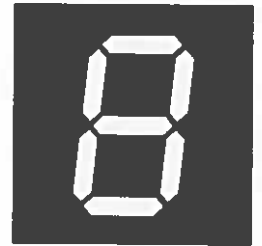

Figure D-1 Error sources in Resistance Measurements

CHAPTER E: GENERAL OPERATION AND DESIGN

- E-1 General
- E-2 Troubleshooting
- E-3 Circuit Descriptions
- E-4 Analog-to-Digital Converter
- E-5 Ohms-to-DC Converter
- E-6 Failsafe Design
- E-7 Ultra-Safe Power Supply Scheme

- Figure E-1. Model 620MG Block Diagram
- Figure E-1B Analog-to-Digital Converter Timing Diagram
- Figure E-2 Analog Section of IC1 and IC2
- Figure E-3. Constant Current Source Diagram (Simplified)
- Figure E-4. LED Display Pin Functions



CHAPTER F: ROUTINE MAINTENANCE

- F-1 General
- F-2 Required Test Equipment
- F-3 Calibration Procedure

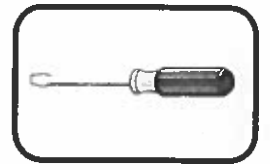

SECTION A - RECEIVING AND INITIAL INSPECTION



A-1. Introduction to the AMPTEC 620MG

The AMPTEC 630, 640 and now the 620 Series Igniter Testers/Failsafe Ohmmeters are becoming the standard in the Safety Igniter Circuit Test industry, and are designed to provide extremely safe and reliable resistance testing of explosive or volatile devices. Safety Approvals from various Safety Boards include, the U.S. Air Force (620A-4) for generic use on Non-Nuclear munitions and the US NAVAL ORDNANCE CENTER (630BN, 640N and other versions pending). Some of the devices the 620MG Igniter Tester may be used on include: fuses, squibs, igniters, explosive bolts, rocket motor squibs, automobile air-bag initiators and many others.

The AMPTEC 620MG is a 4-wire failsafe digital ohmmeter which has been designed to reliably use very low test currents for its resistance measurement. Failsafe Output Circuitry proprietary to AMPTEC RESEARCH ensures that test current levels do not exceed the specified "failsafe current" even in a worst-case component failure situation. The failsafe feature is tested in every instrument before shipment.

The newer 620 series represent the latest in ultra-safe Igniter Tester measurements. The 620LM fundamentally uses the same main printed circuit board (PCB) as all of the AMPTEC 620A Igniter Testers. The 620MG has many features which make it useful in a variety of applications. Please check the last chapter of this manual for addendums that may apply to the 620MG.

A-2. Receiving, Unpacking, and Initial Inspection

Should the AMPTEC shipping box appear damaged upon arrival, request that the carrier's agent (i.e. UPS) be present when the unit is unpacked. If the 620MG appears damaged, the carrier's agent should authorize repairs before the unit is returned to the factory. Even if the instrument appears undamaged, it may have suffered internal damage in transit that may not be evident until the unit is operated or tested to verify conformance with its specifications.



If the unit fails to operate or fails to meet the performance specifications of Section B, notify the carrier's agent and the nearest AMPTEC Sales Office. Retain the shipping carton for the carrier's inspection. **DO NOT return equipment to AMPTEC RESEARCH** or any of its sales offices *without first obtaining* an (RMA) Return Material Authorization number. We need to know who to contact and how to contact (i.e. phone number and FAX number) in order to properly coordinate the return of the repaired AMPTEC product.

By calling AMPTEC RESEARCH first, prior to just returning the 620MG, we can often troubleshoot (based on the symptoms you describe) and identify the problem over the phone (i.e. battery loose in the battery holder).

We may possibly be able to fix the problem over the phone and prevent you from having to return the unit to AMPTEC for repair.

A-3. Isolated Continuous Operating Power -

Isolated continuous operating power for the AMPTEC 620MG Igniter Tester is derived via a multiple levels of isolation electronics and circuits for safety reasons (not D cell battery power). There is a AC/DC Wall Adaptor with a special polarized Molex connector that provides the first level of isolated 24 VDC input (rear panel) into the meter. This AC/DC Wall adapter accepts 115 VAC input (60Hz) and provides basic wideband AC Noise Isolation and a conditioned 24 VDC input for the meter.

The isolated AC/DC Wall adapter is fitted with a polarity keyed box type Molex connector plug # 436040-0200. This helps prevent the accidental use of any non approved AC/DC Wall Adapter from being plugged into the AMPTEC 620MG rear panel power port (Molex 436040-0200 mate connector)

Inside the meter is DC/DC Isolation circuitry with 3 KV of isolation from the input DC voltage. This internal circuitry provides a conditioned 6 VDC to operate the meter's measurement circuitry.

A-4. Setup and Use

The AMPTEC 620MG Igniter Tester may be setup to operate within minute(s) of power "turn on" (unless your in an extremely cold temperature - allow more time for warm-up - 15 minutes).

The AMPTEC 620MG consumes little power and generates virtually no heat. Consequently, it may be used in any area where the environment does not exceed the specifications of Table B-2.

Avoid exposing the AMPTEC 620MG to extremes of temperature which will affect accuracy and stability of the product.

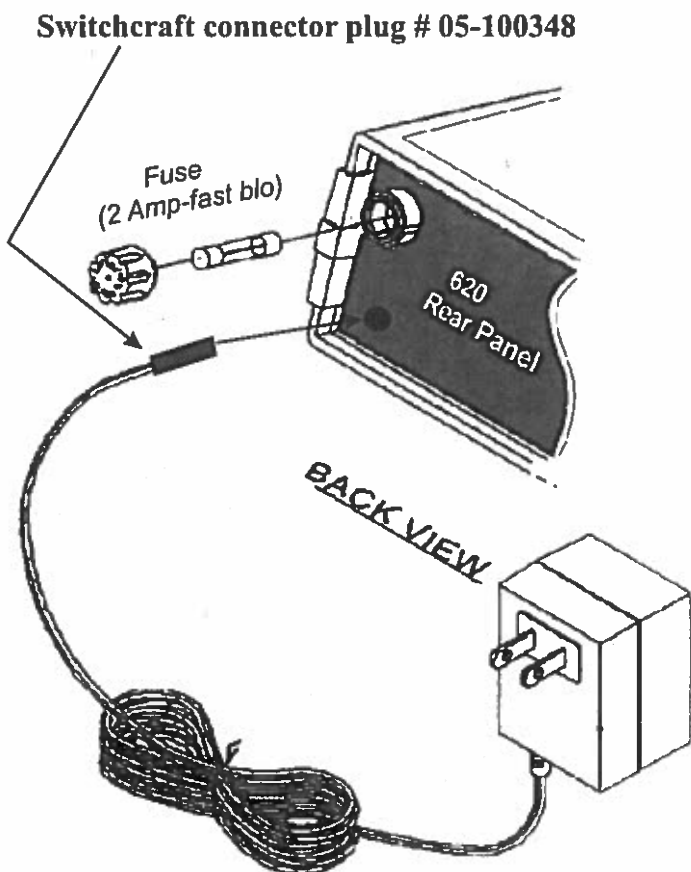

AMPTEC 620MG EXPLOSIVE SAFETY IGNITER TESTER - SPECIFICATIONS



Continuous Decade Resistance Ranges (No Gaps) from 2.0 Ohms to 2.0 Megohms Fullscale

2Ω	20Ω	200Ω	2000 Ω	20 KΩ	200KΩ	2 MΩ	Resistance Range
5 mA	5 mA	500 uA	50 uA	5 uA	0.5 uA	0.5 uA	Test Current
8 mA	8 mA	8 mA	8 mA	8 mA	8 mA	8 mA	Fail Safe Current
0.1 mΩ	1 mΩ	10 mΩ	0.1 Ω	1 Ω	10 Ω	100 Ω	Ohms Resolution

**620MG Resistance Range / Nominal Current/Failsafe Current
and Display Resolution Table**

Table B-1 Specifications

Accuracy: (for 1 year @25°C ± 10°C)

- 2 Ohm range - 20K Ohm ranges ±0.02% of reading ±0.02% of range
- 200K Ohm ranges ±0.02% of reading ±0.05% of range
- 2.0 MOhm ranges. ± 1.0 % of reading ± 0.2% of range

Temperature Range

- Operating 0°C to 50°C
- Storage -10°C to 70°C

Temperature Coefficient

- 2 ohm through 200 ohm ranges ±0.002% per °C (from 0°C-15EC and 35°C-50°C)
- 2.0 Megohm range ±0.01% per °C (from 0°C-15EC and 35°C-50°C)

Instrument Display .. (20,000 count) 4½ digit Super Bright Light Emitting Diodes (LED)

Over-Range Indication (select next higher range) 620VN Display flashes

Measurement Update Rate Approximately 300ms

Open Circuit Current Source Compliance Voltage clamped at ~1.6 volts

DC Power - The AMPTEC 620MG safety meter is normally configured with (2 Stage Isolation) OP247 Isolated Continuous Operating Power .

Remote Control Interface - The AMPTEC 620MG safety meter is normally configured with the option "232" an optically Isolated Serial Interface. It that allows computer/controller to remotely send I/O commands that make the 620MG change ranges to the desired range and give back resistance readings via a rear panel RS232C interface/connector. See section in this manual for available I/O commands and format detail.

Dimensions 9.0" (23cm) W x 9.0" (23cm) D x 3.0" (8cm) H

Weight 4 lbs net; 10 lbs shipping (without transit case)



SECTION C OPTIONAL ITEMS AND ACCESSORIES

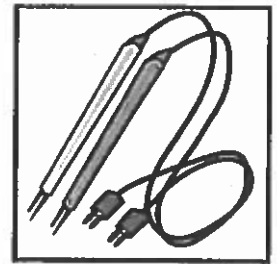

C-1. Available Accessories and Options

Listed below are the options available for use with the AMPTEC 620A Series FailSafe Ohmmeters.

Option 620MG-DC: AC Power Adapter Line Conditioner

Option "620MG-DC" is an AC/DC Wall adapter that safely converts and conditions 115VAC line voltage to 24VDC at 300mA. One adapter is provided as a standard accessory with every 620MG. It is fitted with the mating Molex connector that is specifically compatible with the meters rear panel molex connector. Additional Isolation electronics is inside the AMPTEC 620MG but this particular AC power adapter has been shown to continuously provide isolated DC power (to 3 KV AC and 3 KV DC) for the AMPTEC 620MG Igniter Tester.

Option 100: Carrying Case

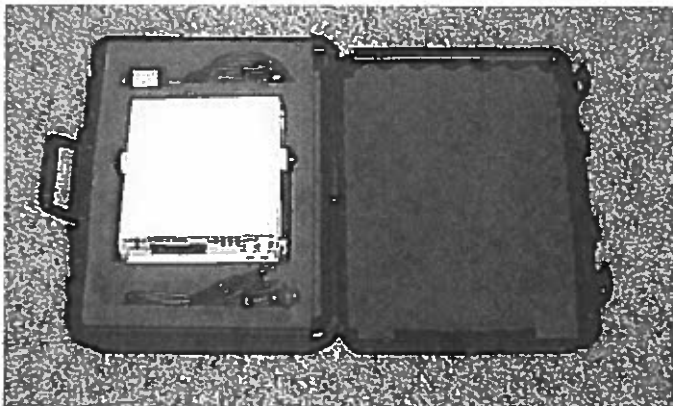

Option "100" is a hardshell (impact resistant plastic) shock absorbing foam lined meter and accessory carrying case for the 620A Ohmmeter with extra room for test leads, battery charger, Kelvin Clip Test Leads, Connector Adapters, single pointed probes and operator manual etc.

Option RACK: Rack Mount Adapter

Option "620RACK" includes an adapter tray that allows any AMPTEC 620 series tester to be flush panel mount installed in a standard 19" NEMA equipment rack.

Option "500" Optically Isolated Analog Output

This rear panel mounted isolated analog DC Voltage output signal is directly proportional to the 620 tester's ohm display measurement. (i.e. 1.2345 VDC for 12.345 ohms). It is used to track 620 tester measurements for datalogging purposes with an external device (i.e chart recorder, system DMM with GPIB). Isolation protection is rated @2000 volts peak to insure any instrument connected to "Option 500" has virtually no impact on the 620 series tester's safety.

New Options and Custom Leads Available

Contact the sales department at AMPTEC RESEARCH (phone 1-800-350-5105) if you have need for a special probe, adapter, lead set, or custom option not listed in this manual. AMPTEC'S experienced application engineers have helped supply many customers with special igniter tester accessory requirements.



CHAPTER D - OPERATION, FUNCTIONAL AND USE

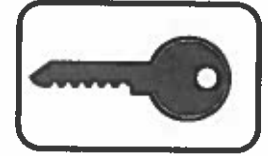

D-1. General Operation

This section contains operating instructions for the AMPTEC 620MG Explosive Safety Igniter Tester.

D-2. Front Panel Features and Operation

Main Power Switch

The AMPTEC 620MG Igniter Tester was designed for automated RS232C use (range changes and measurements via isolated serial computer interface). The AMPTEC 620MG Igniter Tester is always hardwired 'ON', there is no power ON / OFF switch. When proper power is applied to the Locking rear panel Switchcraft connector, the meter is 'ON', when rear panel power input is plugged in and the front panel power switch is "ON". Although this "power" is also further isolated and conditioned inside the meter, this (special switchcraft jack rear panel input) is the only source of power for the AMPTEC 620MG.

Range Switches

The AMPTEC 620MG has **range switches** to select each range manually. To operate the diode test deselect the Manual Range switches and press the momentary Diode Test switch. Deselect the Manual Range switches to operate the RS232.

Over-Range Indication

If the resistance being measured (including "Open Circuit/ Disconnected states") is a higher value than the selected range, the instrument's display will **flash (blink)**, which indicates "overrange".

Gold Plated Rear Terminal Inputs

The AMPTEC 620MG has no front panel connections. All resistance measurement inputs are via the rear panel terminal strip. The AMPTEC 620 user can directly connect a bare wire to the appropriate terminal screw (**Voltage High** and **Voltage low**, and **Current high** and **Current low** labeled as **Vhigh, Vlow, Ihigh, Ilow**).

Calibration Access Screws

Recessed in the four feet on the bottom of the AMPTEC 620MG you will note there are 4 screws (Phillips head type) that are used for calibration access. These screws are meant to remain intact and should only be removed by authorized personnel (i.e. Calibration Lab staff).

Optional Functional Test Box with built-in milliammeter

An optional Functional Test Box (option FTB-620ES) for the AMPTEC 620MG contains an analog 10 mA full-scale milliammeter and a variety of test resistors is available from AMPTEC RESEARCH.

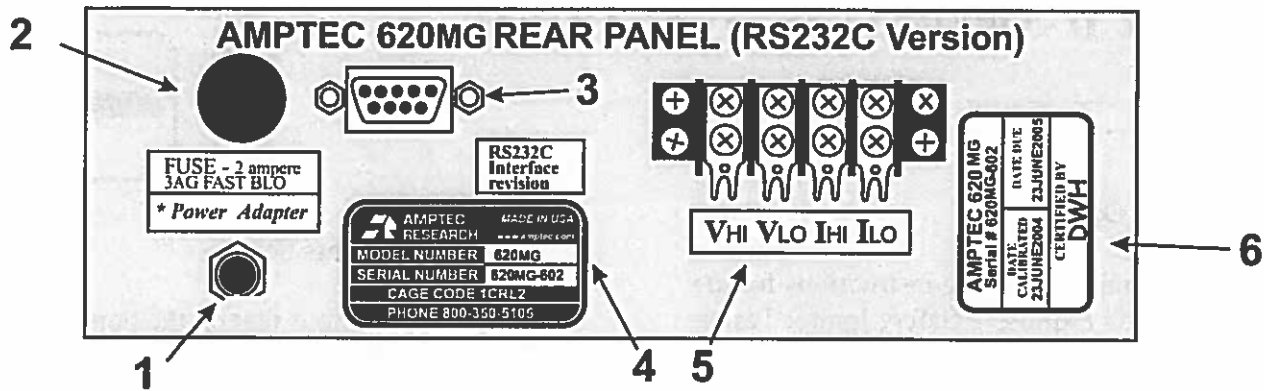

AMPTEC 620MG Rear Panel with RS232C I/O

Item 1 - The AMPTEC 620MG rear panel (shown above) contains many jacks, terminals, labels, and stickers.

* The special AC to DC Adapter (item #1) must be left in the rear panel jack in order to operate the meter, as it is fitted with option "247" (Isolated Continuous Operating Power). The isolated AC/DC Wall adapter is fitted with a Switchcraft Power connectors Plug in and Screw to lock. This helps prevent the accidental use of any non approved AC/DC Wall Power Adapter from being plugged into the AMPTEC 620MG rear panel power port (Switchcraft PN 761KS12 mate connector).

Item 2 is the fuse holder - replace with a 2 ampere 3 AG type fast blow fuse (rarely needs replacing).

Item # 3 - RS232C Serial Interface is a safety isolated RS232C serial I/O with 9 pin D type Sub-min connector. This RS232C Interface provides the meter's resistance measurements to a PLC fitted with a serial port. The **RS232C protocol settings should be 9600 Baud, 8 Bits, No parity, 1 Stop Bit, 9 pin D Sub-min connection.**

RS232C Command Set

Note commands are case sensitive.

C Continuous Read Mode - RS232C I/O outputs a data string every A to D conversion cycle, approx. 2.5 times per second.

S Single Read Mode - RS232C I/O outputs a single data string upon reception of a "R" command.

R Read - Commands RS232C I/O to output a single data string (1 resistance reading).

- A** Selects Auto-Range mode
- r0** De-Selects all Ranges
- r1** Selects the 2.0 Ohm Range
- r2** Selects the 20 Ohm Range
- r3** Selects the 200 Ohm Range
- r4** Selects the 2K Ohm Range
- r5** Selects the 20K Ohm Range
- r6** Selects the 200K Ohm Range
- r7** Selects the 2M Ohm Range
- D,d** Selects the **Diode Test** function

Data Format - The RS232C I/O outputs a data string with the following format:

1.2345E+3 The measurement is usually in Ohms (where $E+3 = 10^{+3}$ scientific notation style). The Exponent is defined below. $1.2345E+3 = 1.2345 \text{ KOhms}$ (where $E+3=10^{+3}$). $1.3700E+1 = 13.700 \text{ Ohms}$ (where $E+1=10^{+1}$)

Range	Exponent
2.0 Ohm	E+0
20.0 Ohm	E+1
200.0 Ohm	E+2
2.0 K Ohm	E+3
20 K Ohm	E+4
200 K Ohm	E+5
2.0 MOhm	E+6
Diode Test	E+0

Overrange is indicated by 9.9999E nn . Where nn is the selected resistance range exponent. A Range Error is indicated by x.xxxxERR.

Item # 4 is the unit's serial number sticker.

Item # 5 is the gold plated 4 terminal rear terminal strip (they are wired in parallel with the front terminals). If a "2 wire ohms" connection is made then the V high and I high terminals should be shorted together, and the V low and I low terminals should be shorted. The 620MG Voltage High, Voltage low, Current High and Current Low wires are permanently connected to the gold plated rear terminal strip (see labeled gold plated terminal strip on rear panel).

Item #6 Calibration Sticker - If the calibration due date has expired (1 year) AMPTEC or a Cal. Lab can contacted to re-certify the AMPTEC 620MG Explosive Safety Ohmmeter/Igniter Tester. contact AMPTEC customer service see website www.amptec.com

D-3. 4-Wire Resistance Measurement

The four-terminal configuration of the 620MG eliminates measurement errors normally caused by "in series" test lead resistance and "contact" resistance.

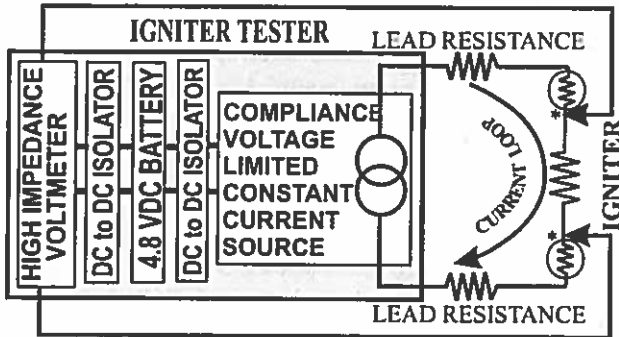

* contact resistance
Figure D1 - Igniter Tester Kelvin Block Diagram

In many resistance measurement applications the contact resistance and can exceed the value of the test resistance by several orders of magnitude. The AMPTEC 620MG overcomes this potential error source by providing two terminals of constant current (I_{high} and I_{low}) and an additional two terminals for high impedance voltage measurement. The constant current source uses a variable compliance voltage circuit to overcome lead and contact resistance until the current loop is a constant level. The result is a fast, accurate resistance measurement of the test resistance, independent of the resistance of the current carrying leads.

Figure D-1 above illustrates the 4-wire principle eliminates lead, wire and contact resistances as potential error sources. The internal constant current source inherently overcomes all series resistance (within compliance voltage limits) and delivers a precise constant current. *Separate DC to DC isolation circuitry provides independent circuit voltage supplies for both polarities of the constant current source circuit.* The internal high-impedance Digital Voltmeter (DVM) senses the voltage drop across the test resistance (i.e. squib or detonator). There is negligible contact and lead resistance error created by the voltage measurement because the high input impedance of the DVM limits current flow in the voltage (V_{hi} and V_{low}) leads.

D-4. Connections

Connections are made to the front panel terminals using a 4-wire configuration as described in section D-3.

Next connect the 4 wire Kelvin wires or test leads into the AMPTEC 620MG Igniter Tester rear panel.

For 620 series test leads other than those terminated with banana plugs, RG-58 Shielded Coax Cabling is recommended. Customer built test wiring should maintaining the four wire Kelvin measurement if possible. Make the current conductor the largest conductor and keep the voltage sense input shielded or inside the current shield. The AMPTEC 620 series Igniter Tester's five way input jacks allow for customized wire connections, extended kelvin wiring (beyond 100 feet depending upon conductor gauge), cables terminated with spade lugs, and special banana jacks can all be used with most AMPTEC 620 series Igniter Testers.

All AMPTEC ohmmeters use a high impedance voltmeter as part of the resistance measurement process. This voltmeter is a highly accurate and stable $4\frac{1}{2}$ digit analog-to-digital converter (A to D). The high impedance DVM must receive a voltage drop in order to display the proper value. When the DVM is not receiving a definite input signal, the output reading from the Analog to Digital Converter can appear random and wandering. The display may indicate a randomly wandering number or it may indicate an overrange (flashing) condition. This unpredictable display (No input to the DVM) condition is not a malfunction, in fact, just a characteristic of the high impedance voltmeter circuit and *should not be mistaken for a fault in the instrument* -

- - - - - continued next page - - - - -

As this condition is simply a state of an "open circuit" or "nothing connected" to the DVM circuitry. A flashing display (on and off usually all zeros) indicates an over-range condition whenever the test lead terminals are open, or the resistance under test is a higher value than the range selected on the AMPTEC 620 tester. *Connecting V_{HI} to I_{HI} and V_{LO} to I_{LO} eliminates the wandering (open circuit) display condition.*

By using a 4-wire Kelvin type lead set or by shorting the V_{HI} and I_{HI} terminals together and V_{LOW} and I_{LOW} terminals together the instrument is in the 2 wire resistance mode.

Resistance Offset in 2 Wire mode

All wiring including harness wires from the two wire test connection out, are "in series" with the test squib resistance and become part of the actual two wire measurement (*another potential source of measurement error if not compensated for*). Many Ordnance test procedures have the 620 series Igniter Tester user short their wiring harnesses at the very end (by the squib) and record the resistance value or offset. Then when the 620 series Igniter Tester leads, including the in-series harness wiring resistance, is connected to the test squib, the squib test resistance can be calculated (via subtraction of the 2 wire harness - test lead resistance offset).

That is the 2 wire lead length shorted offset resistance (without the squib resistance) can be subtracted for the total resistance (including the squib resistance) to determine the actual squib (test) resistance.

Identifying a Test Connection problem

A precision 1.0 Ohm test resistor can be used for testing mid-scale performance of the 2.0 Ohm range. Performing a similar Functional Test with the 620MG meter across the 1.0 Ohm test resistor should get a reading close to 1.00 Ohm (i.e. 0.9995 Ohms is OK). If the 620 Series Igniter Tester appears OK after checking each range against a known resistance then the connection problem must be outside of the 620 series meter (i.e. your wiring harness or the actual device under test connection.) If the 620 series meter doesn't agree with the test resistors, then the meter or its test leads are most likely broken.

If this case, please contact your local AMPTEC RESEARCH Service Office, or call 1-800-350-5105 or +1(512) 858-4045 (International Overseas) or FAX+1(512) 858-4340, email info@amptec.com

The AMPTEC 620 display should indicate a stable reading when the test leads are securely attached to the device under test. If the display appears to be erroneous when connected to the resistance under test, recheck the test leads for integrity and cleanliness. If all external items appear to be functioning properly, the next step in problem isolation and diagnosis involves general trouble-shooting principles. If a measurement problem appears on the 2.0 Ohm range of the meter, test for a zero offset problem first. Plug the 620 with Kelvin test leads into a 0.10 test resistor (i.e. AMPTEC # FTB-620ES). If the meter doesn't display a value close to 0.1 Ohms adjust the zero (see calibration procedure chapter). The zero adjustment trimpot only has enough span to zero out the 620 series test leads. The meter's zero adjustment pot wasn't designed to zero out a 100 feet of 2 wire harness.

D-5. Failsafe Operation

The AMPTEC 620MG Igniter Tester uses a fail-safe constant current source design that renders them incapable of delivering excessive voltage or current to the device under test. The typical fail-safe current for each range is indicated with most AMPTEC models under the corresponding range switch on the 620 series meter front panel. Please refer to section E-6 for a technical description of the failsafe circuitry specifics.

As a further precaution the 620MG Igniter Tester is line isolated from the AC line to 3 KV DC or AC when only used 620MG-DC AC wall Power Adapter/conditioner (supplied with the meter).

As this meter is fitted with the Diode Test function the nature of this circuit uses higher compliance voltage. As a result the failsafe current limit is 25 mA.





E-1. General

The AMPTEC RESEARCH 620MG Explosive Safety Igniter Tester is shown in the block diagram (Figure E-1). All diagrams and information disclosed in this chapter is proprietary and is included in order to make troubleshooting to component level possible.

The AMPTEC 620 Series Igniter Tester uses modern solid-state semiconductors exclusively and digital CMOS circuits extensively to minimize power requirements and make battery operation useful and practical. AMPTEC also maintains a spare parts inventory of all components found in the 620MG Tester and its customer service department can also provide additional assistance in the trouble shooting process.

E-2. Troubleshooting

Since the 620MG Tester is used to test potential deadly explosive force detonators and warheads of missiles etc., *personnel that are not qualified to make such electrical repairs on the 620LM Tester should not even attempt to remove the calibration access screws or open the main panel or effect any repair whatsoever.*

Apparent 620MG Tester malfunctions can sometimes be the result of bad test lead/connection wiring, wrong connections, misinterpretation of specifications, low battery levels, and in rare cases due to an incomplete understanding of the instrument and how to use it. A thorough review of the operating instructions for this instrument is recommended prior to any component replacement. Check to be sure that cables and other test equipment are in good working order before attempting to troubleshoot the 620MG series igniter tester .

If you turn on the AMPTEC 620MG Explosive Safety Igniter Tester and the display does not come on, it usually means the batteries are dead and need charging, or fuse needs replacing.

If the 620MG exhibits problems that cannot be eliminated by reviewing Chapters B and D, the following guidelines have been established to help solve the problem.

E-2-1. Localizing the Problem

Chapter D-2 discusses how to use the *Functional Test Box (FTB-620ES)* with the 620MG Tester to help localize the problem. The key to successful troubleshooting is to localize the problem to a general electronic parameter as much as possible before trying to pin the problem down to a specific component. Certain questions should be asked such as "Does the problem occur on all ranges or on a specific range only?". If the 620MG Tester does not come on when powered up, did you check the rear panel fuse. The power supplies for both the current source and the digital voltmeter electronics are also one of the first things that should be tested. As it is not possible to anticipate all failure modes of the 620MG Explosive Safety Igniter Tester, servicing personnel should become familiar with this section to gain a complete understanding of the internal workings of the ohmmeter.

E-2-2. Component Replacement

If the malfunction is a faulty component, the accuracy of the 620 Series Igniter Tester can be maintained only if it is re-calibrated after a component replacement and the following precautions are taken:

Use only the specified component or its exact equivalent. Spare parts can be ordered from your nearest AMPTEC RESEARCH Service Center or directly from the factory by referring to the AMPTEC Stock Number listed in the Parts Lists section at the back of this manual.

The highest quality 63/37 grade rosin core electronic grade solder with a 50W or lower maximum power soldering iron should be used. Never use an acid core solder as corrosion of components leads and PCB etch loss can occur.

When soldering, heat the PCB pad and the lead of the component, not the solder. After several seconds of the component lead in contact with the hot soldering iron apply solder smoothly and evenly onto the PCB pad and component lead not the soldering iron. Do not touch or move the replacement part until the solder has cooled. Cold solder and bad solder joints can cause more problems.

Use the chassis ground (connect to the common terminal of the functional test section) connection - i.e. connect to an earth ground to avoid a static discharge to a static sensitive component. Handle all 620MG internal components as if they are static sensitive if you are not sure.

See Next Page for Start of 620 Circuit Descriptions and Functional Diagrams

E-3. Circuit Descriptions

The circuit descriptions which follow are referenced to Figures E-1, E-2, E-3 and the schematic diagrams at the back of this manual. In the following descriptions, references to integrated circuits are given in the form "IC201-1", which refers to Integrated Circuit 201, pin 1.

E-4. Analog to Digital Conversion

The A to D conversion is done with a ICL8068 /ICL71C03 chip set. The ICL8068 takes care of the analog part and the ICL71C03 takes care of the digital part of the 4 1/2 digit 20,000 count dual slope conversion.

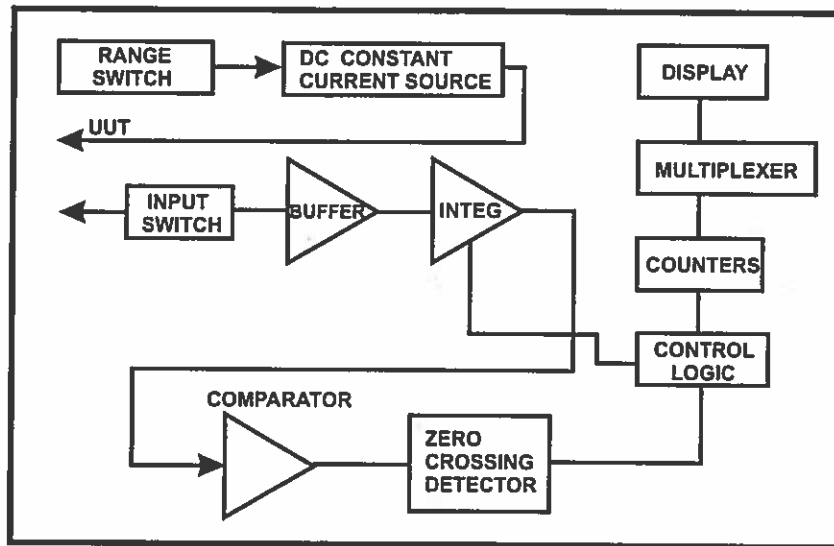

Figure E1 - AMPTEC 620MG FUNCTIONAL BLOCK DIAGRAM

COUNTS			
	PHASE I	PHASE II	PHASE III
4 1/2 DIGIT	10.001	10.000	20.001

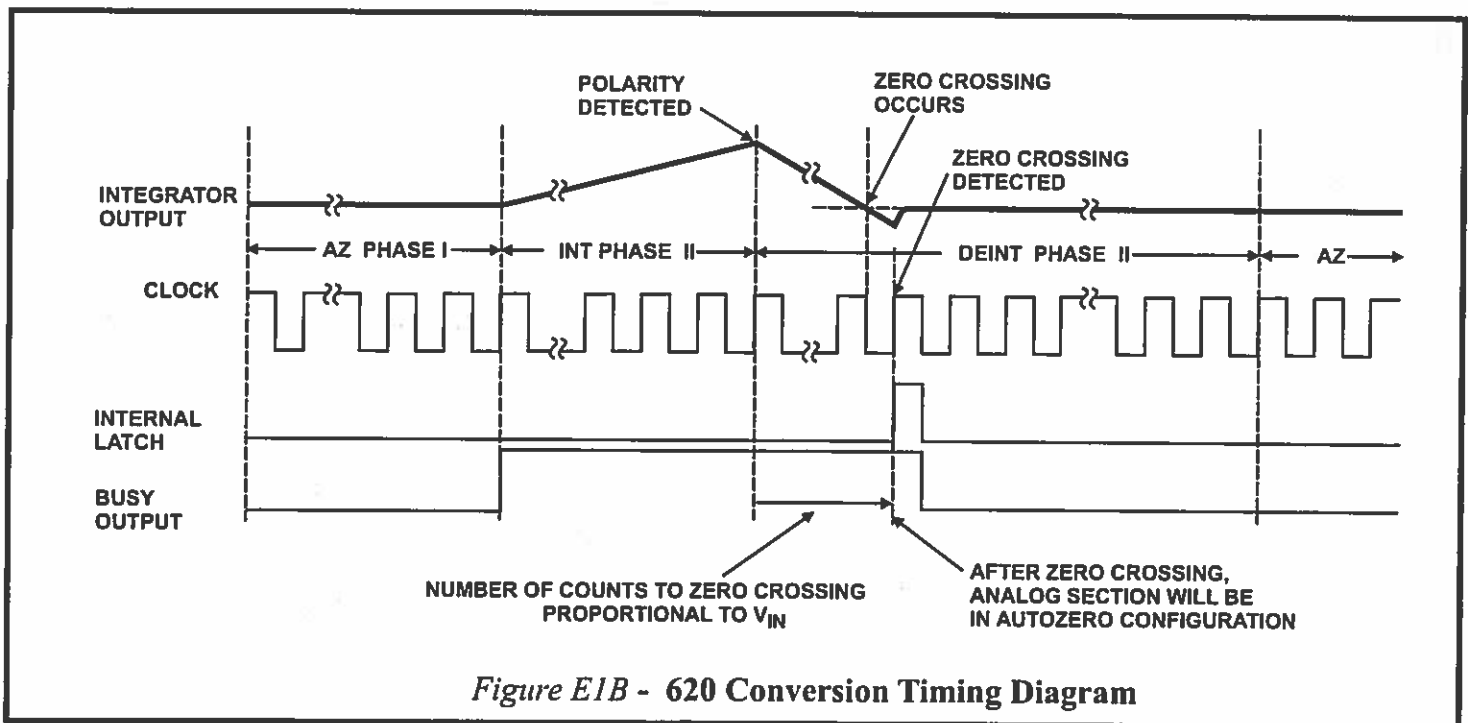
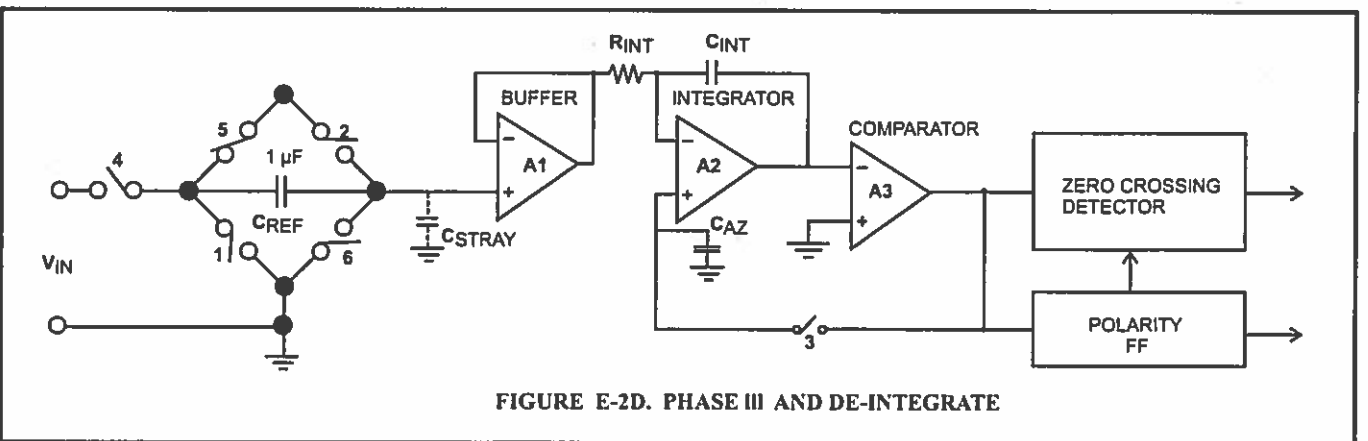
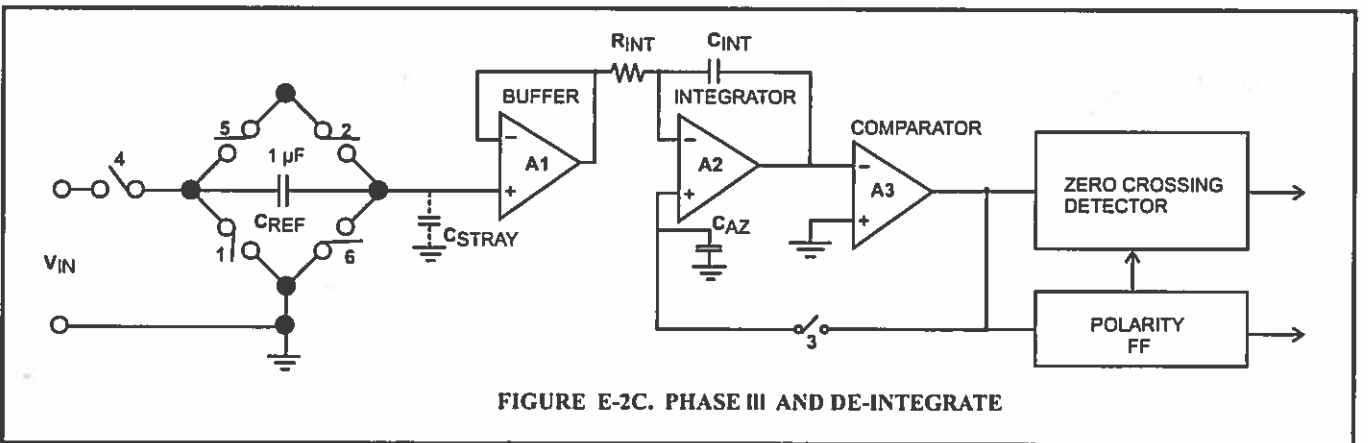
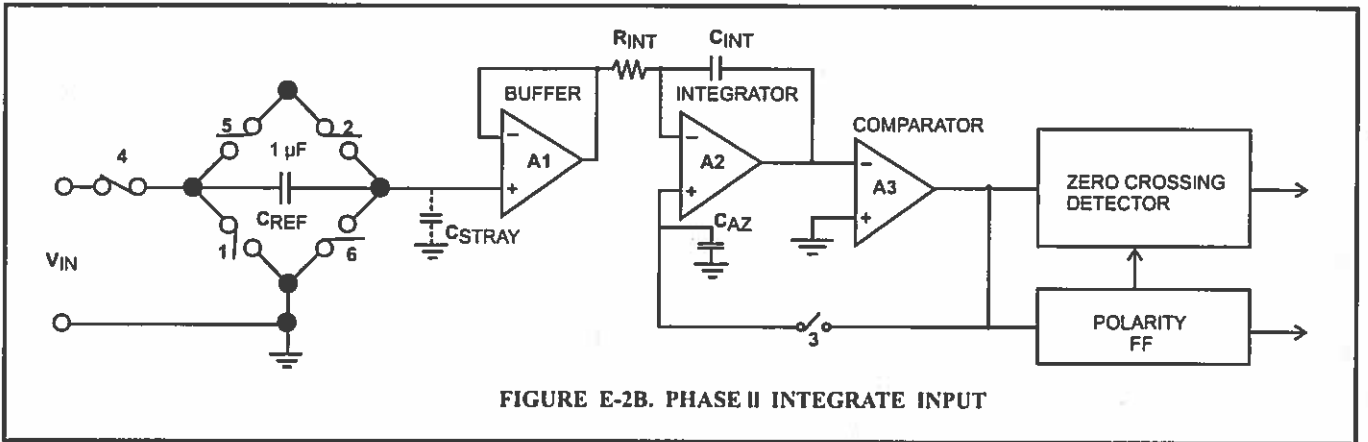
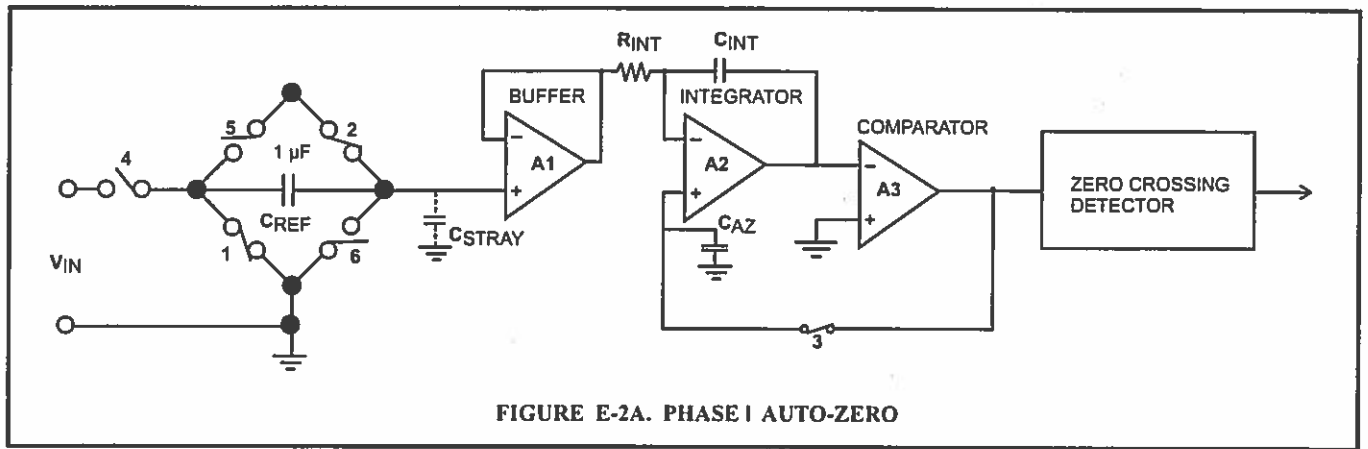

Figure E1B - 620 Conversion Timing Diagram



Figures E2. Main Analog Section of DVM Circuit - IC1 and IC2

Detailed Description

Analog Section

Figures E2 diagrams A thru D shows the equivalent circuit of the analog section in 3 different phases of operation. The system will perform conversions at a rate determined by the clock frequency 40,002 clock periods per cycle. (see Figure E1B shown earlier in this chapter for details of conversion timing).

Auto-Zero Phase I (Figure E2A)

During the Auto-Zero, the input of the buffer is connected to V_{REF} through switch 2, and switch 3 closes a loop around the integrator and comparator, the purpose of which is to charge the Auto-Zero capacitor until the integrator output does not change with time. Also, switches 1 and 2 recharge the reference capacitor to V_{REF} .

Input Integrate Phase II (Figure E2B)

During Input Integrate the Auto-Zero loop is opened and the Analog Input is connected to the Buffer Input through switch 4 and C_{REF} if the input signal is zero, the buffer, integrator and comparator will see the same voltage that existed in the previous state (Auto-Zero). Thus, the integrator output will not change but will remain stationary during the entire input integrate cycle. If V_{IN} is not equal to zero, and an unbalanced condition exists compared to the Auto-Zero Phase, the integrator will generate a ramp whose slope is proportional to V_{IN} .

Deintegrate Phase II (Figures E2C and Figures E2D)

During the Deintegrate phase, switch 5 is closed and a voltage which is V_{REF} more positive than during Auto-Zero is impressed on the BUFFER INPUT. Thus the reference capacitor stores the equivalent voltage. This returns the output of the integrator to the zero crossing point established in Phase I. The time, or number of counts, required to do this is proportional to the input voltage.

E-4-1. Reference Voltage

The precision reference voltage required to do the A/D conversion is developed by IC201. The zener voltage is attenuated to approximately -0.5V. This voltage is applied to IC2-7.

E-4-2. LED Display

The output format from IC2 is in Binary Coded Decimal (BCD) format. Each digit is scanned for 10 clock pulses. The scan sequence is D5 D4 D3 D2 D1. This drives Q1 thru Q5, which in turn drives the seven segment displays. The BCD data is converted to seven segment format by IC4. When the 620MG electronics are in open circuit or over-range mode the display flashes "0000". IC5 is a 1 MHz oscillator which is divided by 10 by IC6. The 100 KHz clock output then goes to IC2.

E-5. Ohms-To-DC Converter

The ohms-to-DC converter generates a constant current which is passed through the device under test to develop the voltage measured by the A/D converter.

E-5-1. Constant Current Source

The constant current source is composed of IC201, IC202, Q202, D203 and their associated components. The input to the constant current source is approximately +1.05 volts, developed at IC201-7 and connected to IC201-13 through R209 and R210. The heart of the constant current source is the voltage-to-current converter. A simplified schematic of this circuit is shown in Figure E-4 and described in Section E-5-2. The amplifier of IC201-12 is an inverter, and its output is applied to IC201-9. The amplifier of IC201-8 has unity gain due to the feedback through R213. Its output is applied to the inverting input of IC202-3. The output of IC202-6 provides feedback to the non-inverting input of IC201-10. This circuit operates to maintain the inverting input at IC202-3 and the non-inverting input at IC202-2 at the same potential.

This applies to all Resistance ranges/mode except for Diode Test Mode

E-5-2 Constant Current Circuit Operation

Assume that terminals I_{hi} and I_{lo} of Figure E-3 are shorted, and 1.0 volt is applied to E_{in} so that I_{hi} is positive. To equalize the 1.0 volt applied to E_{in} , the inputs of IC202, IC201 must be driven to zero. This condition occurs only when the voltage drops across R212 and R222 are equal to the drops across R213 and R221. For these voltage drops to be equal, the output of IC202 must be at +1.0 volt. Since the output of IC201-8 must be zero, the drop across R213 is 0.5 volts, making the inverting input 0.5 volts. The drops across R212, R221 and R222 will also be 0.5 volts. Since the inputs to IC201 are essentially equal, its output is zero (offset by the few microvolts required to drive IC202 to +1.0 volt). Under these conditions the sum of the voltages across R212, R213, R221 and R222 equals the sum of E_{in} plus the output of IC202.

Consider now that the short is removed from the I_{hi} and I_{lo} terminals and a 100-ohm resistor (R_L) is connected in its place. The current through R_L increases the voltage at the input to IC201. A balanced condition will be reached when the output of IC201 is equal to the non-inverting input of IC202. Again, this condition occurs when the voltage drops across R212 and R222 are equal to the voltage drops across R213 and R221. At this time the output of IC202 is 1.0 volts. The voltage drop across the range resistor is 1.0 volt, just as it was when the output terminals were shorted. The current through R_L is 5 milliamperes, just as it was through the jumper when the output terminals were shorted.

E-6. Failsafe Design

Reference to the AMPTEC 620MG Igniter Tester schematic will show that the output of IC202-6 is actually applied to the base of transistor Q202, which acts as a current limiter. *The worst-case component failure that could occur in this circuit would be a Q202 short, which would effectively connect the -5 volt supply directly across R218, D202, the range resistor and R_L .*

D203, however, acts as a 1.6 volt zener diode, limiting the voltage that can appear across these components. Even if every component in the amplifier circuit shorted, the current through the

igniter could not exceed safe limits, because the -5 volt and +5V supplies includes inherent current limiting. Because of the design of both supply isolation transformers T101 and T102, the ± 5 volt supplies can only deliver 20 to 25 milliamperes before the DC/DC converter disengages, dropping the -5 volt output to zero. See Section D.

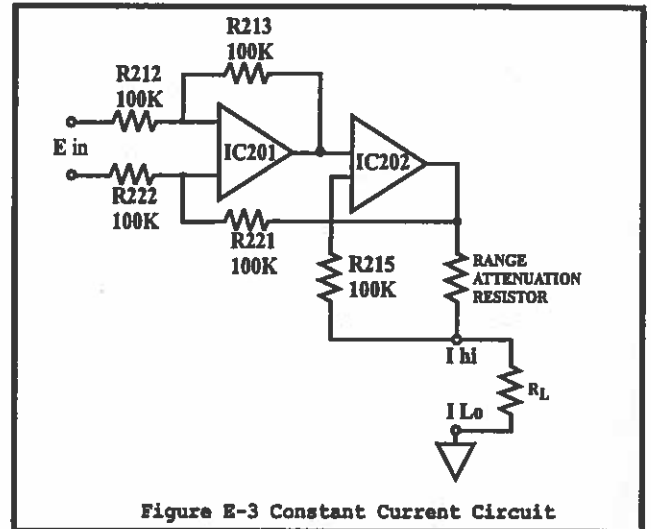

620MG Failsafe Current Calculation - Worst case Component Failure

Voltage limiting diode, D203, provides a 1.6 volts maximum across R227 (10 Ω) and R223 (100 Ω), which are 110 Ohms across the Igniter Testers output terminals.

(I_{max}) Current Maximum Calculation

$$1.6V/110 \text{ ohms} = 0.014 \text{ Amperes} \\ (15mA) \text{ max}$$

The AMPTEC 620MG Tester is powered by a rechargeable internal battery pack and cannot be operated directly from the battery charging adapter. This is to *eliminate the possibility* of an electrical short to/from the AC line. *Only when the 620 POWER switch is in the "OFF/CHARGING" position are the batteries connected to rear panel charging jack. When the POWER switch is in the ON position, the batteries are disconnected from the battery charger and connected to the internal circuits of the AMPTEC 620 Igniter Tester.*

The 620MG Tester measurement circuitry is also failsafe current limited, even under worst case component failure.

E-7 . Ultra-Safe Power Supply Scheme

The +5 volt power supply is provided directly by the batteries (for driving the LED displays and digital logic). The $\pm 5V_D$ is used for driving IC8, the low battery detection circuit. The $\pm 15V$ power supply is generated by IC7 for the digital voltmeter (DVM) chip set (IC1 and IC2).

The $\pm 5 V_A$ is developed by one DC to DC convertor circuitry: composed of Q103,Q104, T102, D103, D104, IC102 for the negative polarity. The other DC/DC convertor is composed is composed of Q101, Q102, T101, D101, D102 and IC101 for the positive polarity.

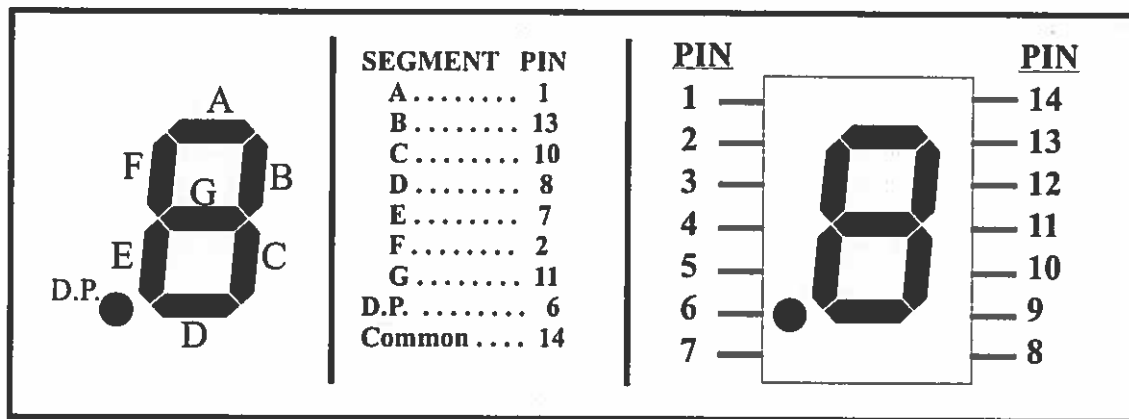
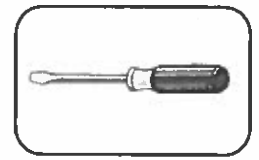

Figure E4 - 620 series LED Display Pin Out Detail/Functions





F-1. General

This section of the manual contains routine maintenance information regarding the AMPTEC RESEARCH 620MG Igniter tester. Calibration should be performed on a regular basis to ensure continued instrument accuracy or following a main PCB electronic component repair/replacement. The recommended calibration interval is 1 year.

The AMPTEC 620MG igniter tester is a four wire Kelvin ohmmeter. *The AMPTEC 620MG Igniter Tester must be calibrated using four wire Kelvin connections to the resistance standard* in order to eliminate lead resistance and contact resistance errors. The rear panel terminal strip (Vhigh, Ihigh, Vlow, Ilow) 4-wire configuration must be maintained up to the point of the connection to the resistance standard (for any range below 200Kohm).

F-2. Required Test Equipment

Following standard resistors are required to calibrate the 620MG Igniter Tester .

Precision Resistors:

- 0.01 ohm \pm 0.01% Accuracy or better
- 1.0 ohms \pm 0.005% Accuracy or better
- 10 ohms \pm 0.005% Accuracy or better
- 100 ohm \pm 0.005% Accuracy or better
- 1.0 Kohm \pm 0.005% Accuracy or better
- 10.0 Kohm \pm 0.005% Accuracy or better
- 100.0 Kohm \pm 0.005% Accuracy or better
- 1 MegOhm \pm 0.10% Accuracy or better
- 14 Kohm \pm 0.10% Accuracy or better

Test Leads:

Rear panel connected 4-wire Kelvin Test Lead wiring (Vhigh, Ihigh, Vlow, Ilow) is needed to eliminate in-series resistance errors or offsets (for calibration and accuracy purposes).

F-3. Calibration Procedure

The AMPTEC 620MG should be calibrated but

The calibration trimpot adjustments are accessed by removing the screws in the feet of the unit, then lifting off the lid. This provides access to the main PCB trimpots. The locations of the adjustments are shown on drawing number 620-600 at the back of this manual. The meter's ranges are selected via (computer command) the optically isolated RS232C serial interface.

F-3-1. Zero Offset Adjustment (20 ohm and higher ranges)

1. Connect the rear panel 4 Wire Kelvin measurement leads to the 10 ohm standard resistor. Using the Range switch, or RS232 select the 2 KOhm range.
2. Adjust potentiometer RV2 for a display indication of 0.0100 KOhms . *Do not over adjust RV2 past a 0.0100 reading.*

F-3-2. Full Scale Adjustment (20 ohm and higher ranges)

1. Still on the 2.0 Kohm range. Connect the Kelvin leads to the 1.0 Kohm standard resistor.
2. Adjust RV1 for a display reading of 1.0000 Kohm.

F-3-3 2.0 ohm range Zero adjustment

1. Using the Range Switch or RS232C interface (commands) select the 2 ohm range. Connect the 4 wire Kelvin leads to the 0.01 ohm standard resistor.
2. Adjust potentiometer RV5 for a display indication of 0.0100 Ohms .

F-3-4. 2 ohm range Full Scale Adjustment

1. Select the 2 ohm range. Connect the rear panel test leads or wiring to the 1.00 ohm standard resistor.
2. Adjust RV6 for a display reading of 1.0000

3. All ranges must be within the specifications outlined in Chapter B. *There are no adjustments necessary for all other ranges.* Contact AMPTEC's customer service department if further technical support is necessary.

F-3-5. 620MG Igniter Tester Diode Test

The diode test function of the 620MG Igniter Tester is for checking diodes. To do this, the voltage compliance output of the constant current supply is increased and the voltage sensitivity of the voltmeter section is decreased.

Using the RS232C interface select the diode test function on the 620MG Igniter Tester. Connect the rear panel measurement test wiring to a 14 KOhm resistor (0.10%). Adjust RV4 for a reading / display of approx. 1.9800 +/- .0100. When connected to a diode such as a 1N4148 or 1N4001 in one direction you should get a reading of about .2700 which is the typically half the voltage drop of the diode (*or divided by 2*). A reading of $.2700 \times 2 = 0.54$ V. In the opposite polarity you should get flashing zeros which indicates "overrange" (out of compliance voltage).

